

AQUAELITE

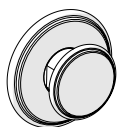

Art. RU202C

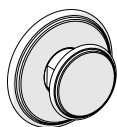

Art. RU203C

CONTENUTO DELLA CONFEZIONE

Package contents / Contenu de l'emballage

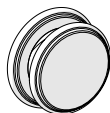
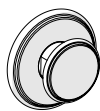

Art. RU202C

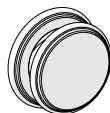
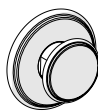

Art. RU203C

UTENSILI NECESSARI

Tools needed / Outils Nécessaires



27 mm

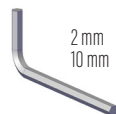

2 mm
10 mm

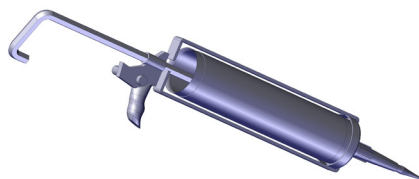

INDOSSARE GUANTI DI PROTEZIONE
WEAR PROTECTIVE GLOVES
UTILISER DES GANTS ISOLANTS DE PROTECTION

INSTALLAZIONE

Installations / Installation

1

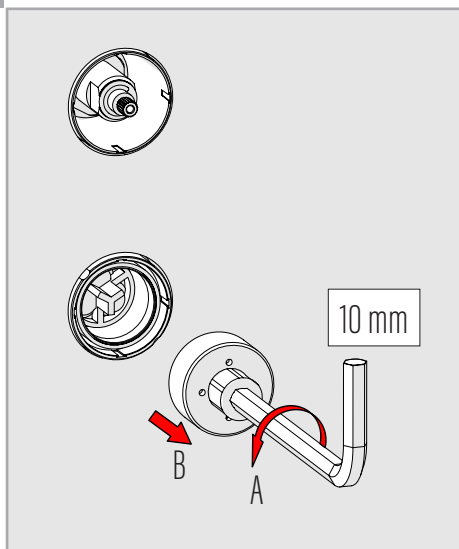

2

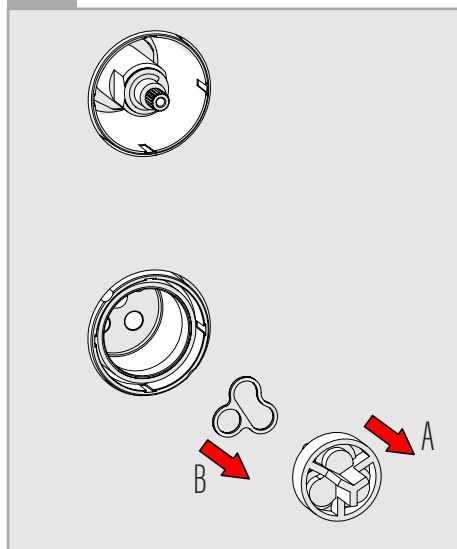

3

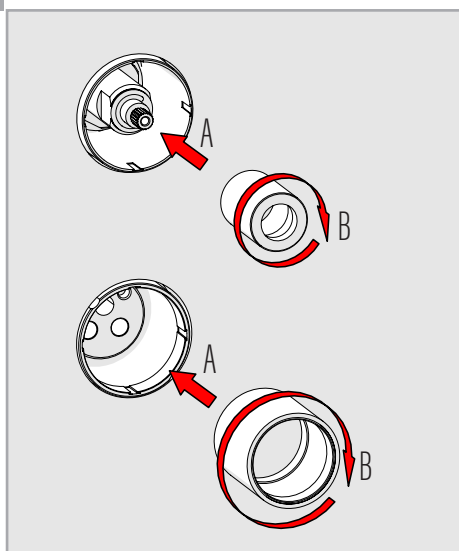

4

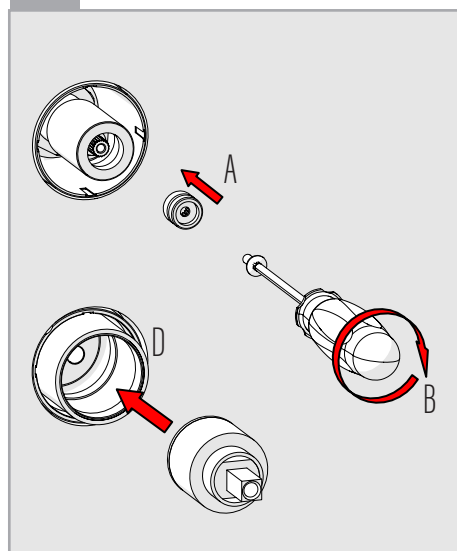

INSTALLAZIONE

Installations | Installation

5

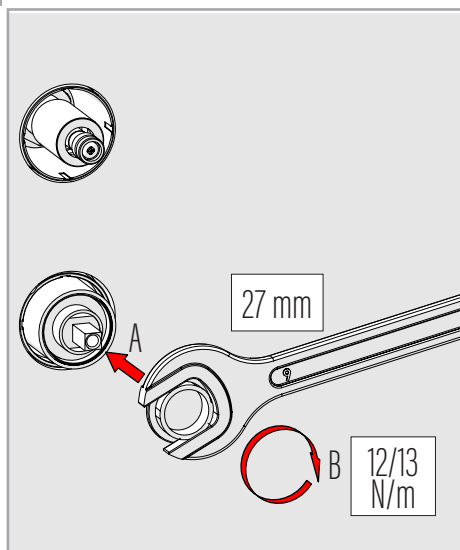

6

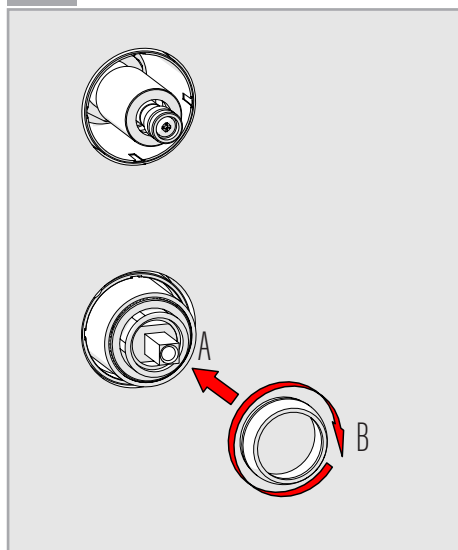

7

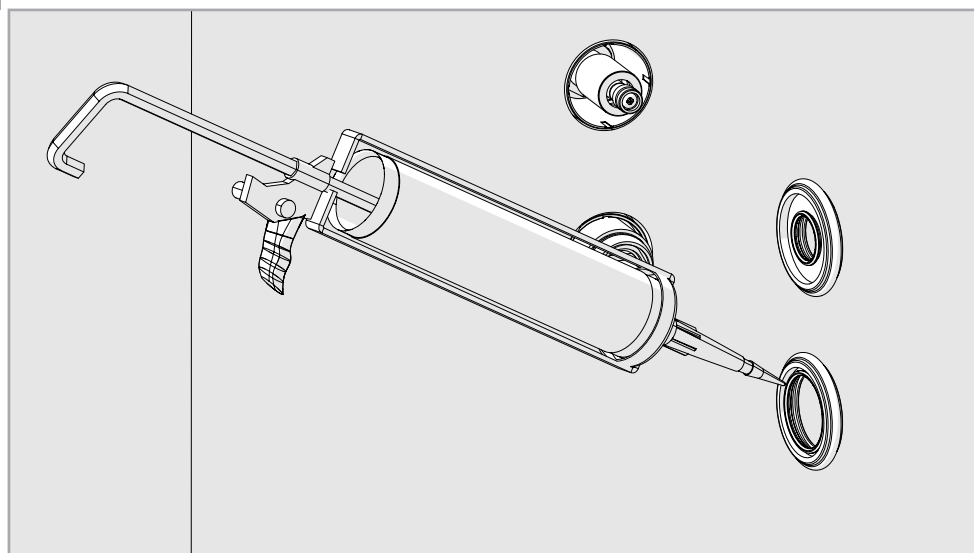

8

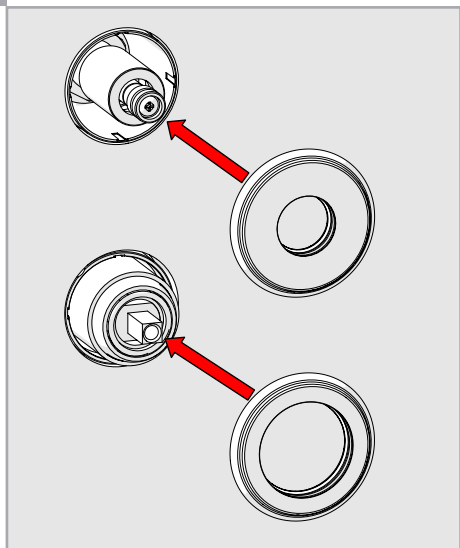

9

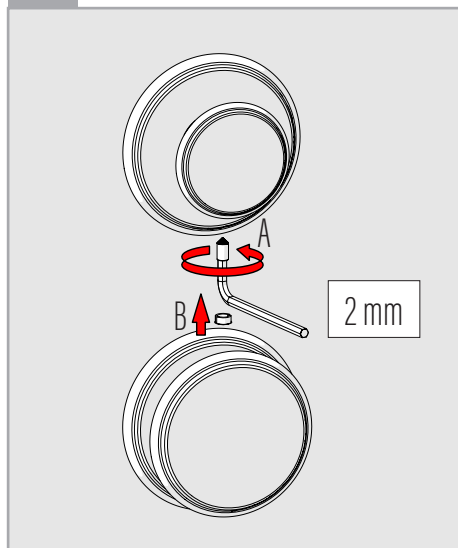

10

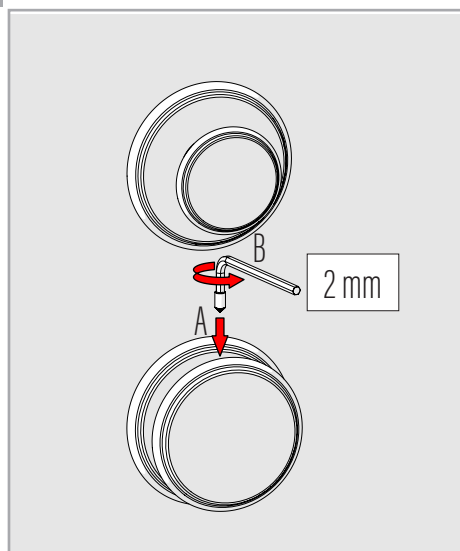

11

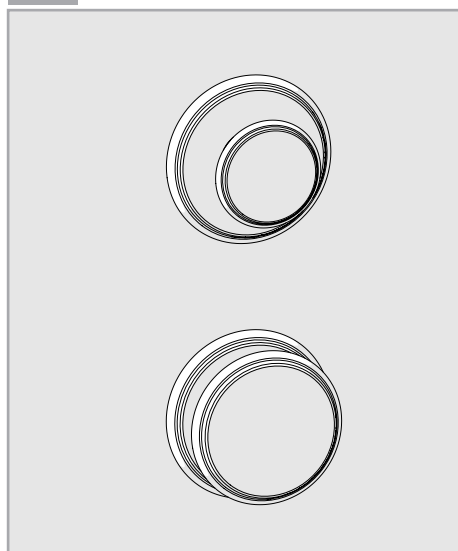

REGOLAZIONI ART. RU202C

Adjustments / Réglages

1

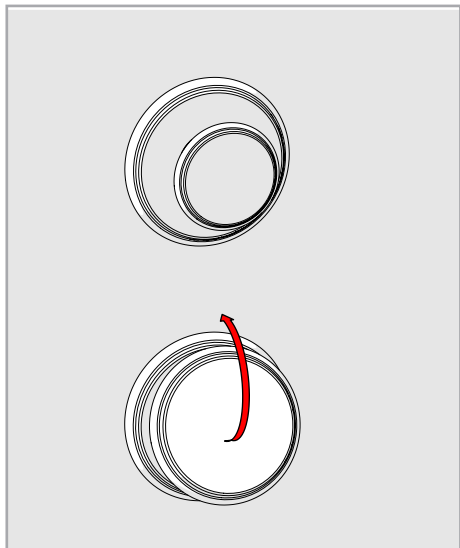

2

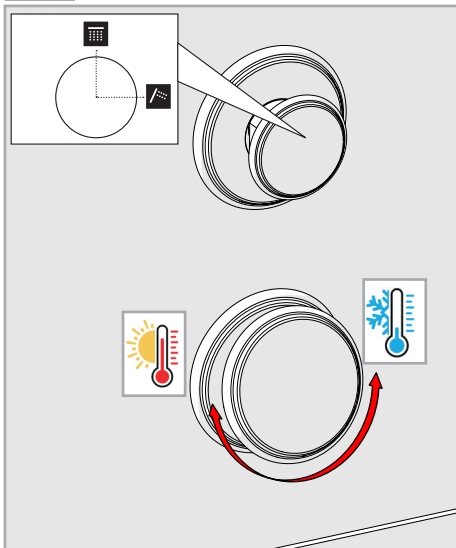

REGOLAZIONI ART. RU203C

Adjustments / Réglages

1

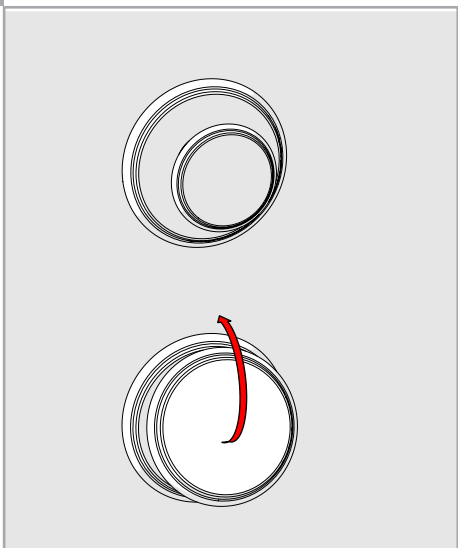

2

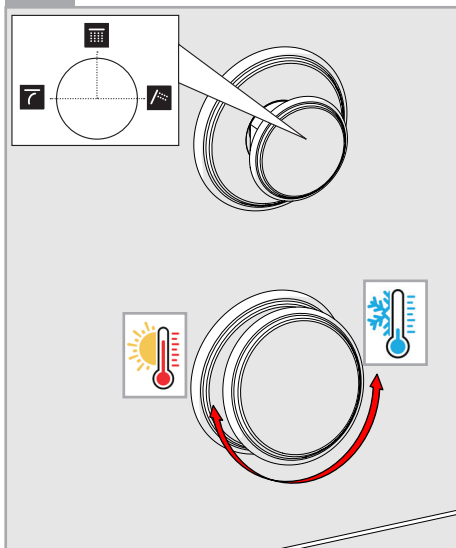

DATI TECNICI

Technical information | Données techniques

Dati tecnici generali per l'impianto idraulico

Pressione minima di esercizio: 1.5 bar
Pressione di esercizio: campo di impiego ottimale consigliato 2.5 - 4 bar
Pressione massima di esercizio: 5 bar
(Per pressioni idrauliche superiori si consiglia l'utilizzo di un riduttore di pressione)
Temperatura massima di esercizio: 65 °C
I soffioni a parete sono dotati di limitatore di portata 12 lt/min. (ove possibile).

Funzionamento minimo dei soffioni ad incasso:

Getto a pioggia: 16 lt/min. - 1.5 bar
Cascata singola: 10 lt/min. - 2 bar
Doppia cascata: 14 lt/min. - 2 bar

Funzionamento ottimale dei soffioni ad incasso:

Getto a pioggia: 18 lt/min. - 2.5 bar
Cascata singola: 14 lt/min. - 2.5 bar
Doppia cascata: 17 lt/min. - 2.5 bar



PROTEZIONE AMBIENTALE

I dispositivi elettrici ed elettronici non devono essere considerati rifiuti domestici. I consumatori sono obbligati dalla legge a restituire i dispositivi elettrici ed elettronici alla fine della loro vita utile ai punti di raccolta collettivi preposti per questo scopo o nei punti vendita.

Technical information for the hydraulic system

Minimum operating pressure: 1.5 bar
Operating Pressure: Optimal recommended use 2.5- 4 bar
Maximum operating pressure: 5 bar
(for higher hydraulic pressure it is recommended a pressure reducer)
Maximum operating temperature: 65 °C
Wall mount shower heads are equipped with a 12 l/m flow rate reducer (where possible).

Minimum supply required for false ceiling shower heads:

Rain function: 16 l/m - 1.5 bar
Cascade function: 10 l/m - 2 bar
Double cascade function: 14 l/m - 2 bar

Optimal supply for false ceiling shower heads:

Rain function: 18 l/m - 2.5 bar
Cascade function: 14 l/m - 2.5 bar
Double cascade function: 17 l/m - 2.5 bar



ENVIRONMENTAL PROTECTION

Electrical and electronic equipment is not to be treated as domestic refuse.
Consumers are obliged by law to dispose of no-longer useful electrical and electronic equipment at the appropriate collection or sales points.

Données techniques générales pour installation hydraulique

Pression minimale d'exercice: 1.5 bar
Pression d'exercice optimale: 2.5 - 4 bar
Pression maximale d'exercice: 5 bar
(pour pressions hydrauliques supérieures, l'utilisation d'un réducteur de pression est fortement recommandée)
Température maximale d'exercice : 65 °C
Les pommes de douche à mur sont équipées d'un limiteur de débit d'eau à 12 lt/min. (ou possible).

Funcionnement minimal des plafonds de douche à encastrer à faux-plafond:

Jet pluie: 16 lt/min. - 1.5 bar
Jet cascade single: 10 lt/min. - 2 bar
Jet cascade double: 14 lt/min. - 2 bar

Funcionnement optimale des plafonds de douche à encastrer à faux-plafond:

Jet pluie: 18 lt/min. - 2.5 bar
Jet cascade single: 14 lt/min. - 2.5 bar
Jet cascade double: 17 lt/min. - 2.5 bar



ENVIRONNEMENT

Les dispositifs électriques et électroniques NE doivent PAS être considérés comme des déchets domestiques.
Les consommateurs sont obligés par la loi à retourner les dispositifs électriques et électroniques, à la fin de leur vie utile, aux points de collecte collectifs faits pour ça ou aux points de vente.

AQUAELITE

AQUAELITE / ANPA S.R.L.
Via Dello Sport, 16/18
2106 Gavirate (VA) - Italy

+39 0322 732 906
www.aquaelite.it
info@aquaelite.it